

CURB MOUNTED SOLAR ATTIC FAN

The Environmentally Sensible Solution that can SAVE you Money!

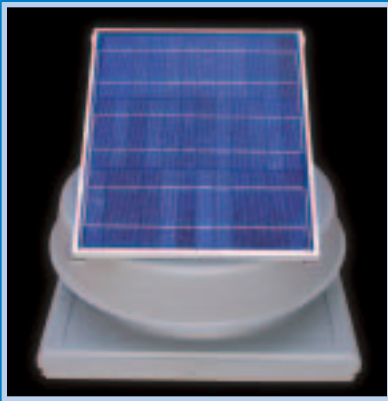

Attic venting is an important aspect in maintaining a healthy energy efficient home or work place. Proper venting cools your roof extending the material life and reduces the load on your air conditioning system. Attic venting also increases fresh air circulation. Powered completely by free solar energy, this sleek and efficient vent is both compact and quiet. It was designed specifically for curb mounted applications for either commercial use or for residential homes. Fully operational right from the box, it installs easily, with no electrical wiring. And let's not forget powerful! Operating up to 1,200 cfm, a single 20 watt unit can fully vent up to 1,800 square feet.



BEST INDUSTRY WARRANTY:
25 YEARS ON THE HOUSING;
15 YEARS ON THE SOLAR PANEL;
5 YEARS ON THE MOTOR

 **Natural Light**
ENERGY SYSTEMS

www.solaratticfan.com

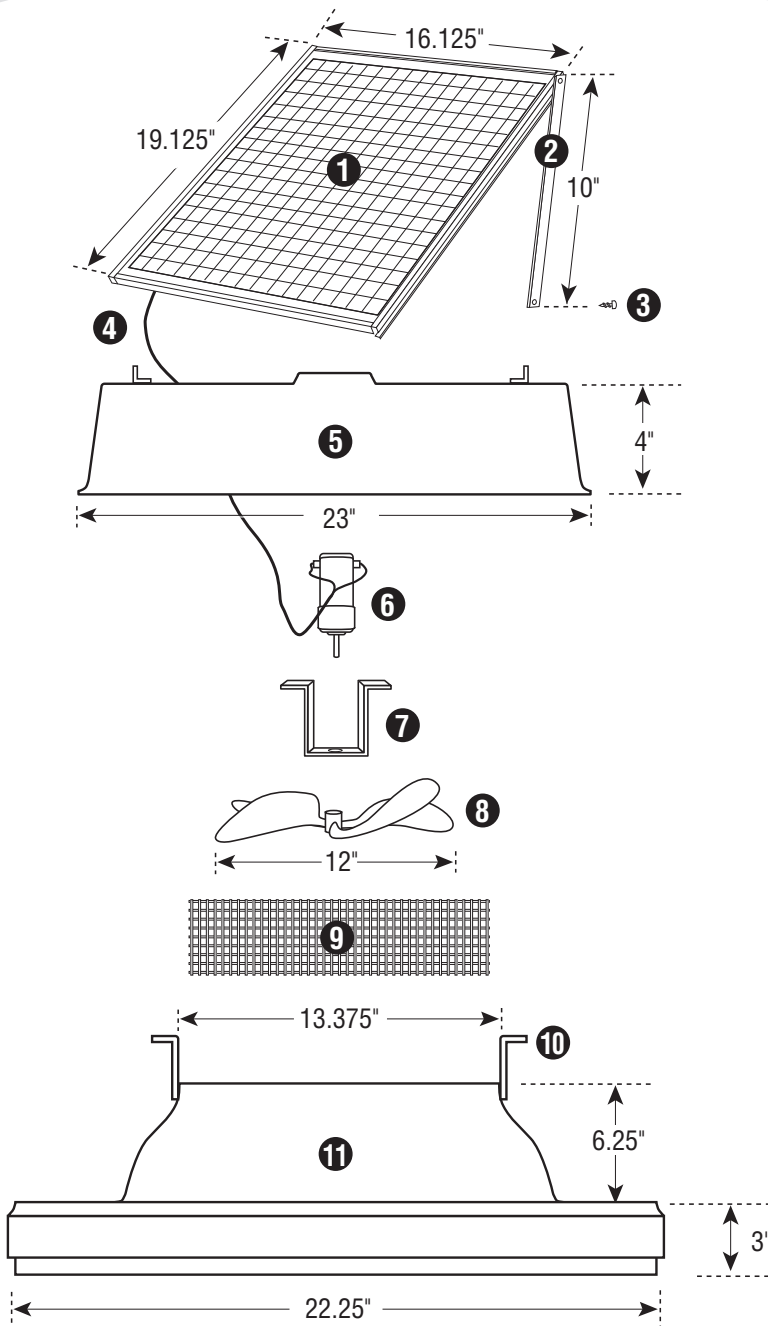

CURB MOUNTED SOLAR ATTIC FAN

NOTE: Exploded view of Curb Mounted Solar Attic Fan is for illustrative purposes only. Unit comes fully assembled.

1. Custom Solar Panel
2. Adjustable Solar Panel Bracket
3. (2) #8 x 1" Self-Tapping Screws
4. Wire Lead
5. 1100 Series, .080" Thickness, Aircraft Grade Aluminum Shroud
6. Custom DC Motor
7. Motor Isolation Bracket
8. Air Drive Precision Pitch Blade
9. 4" x 48" Stainless Steel Wire Mesh
10. Rugged 14 Gauge Shroud Support Bracket
11. 1100 Series, .080" Thickness, Aircraft Grade Aluminum Flashing

OPTIONAL ACCESSORY: Thermal Snap Switch available to automatically turn off unit during colder months.

VENTING CAPACITY

up to 1,800 sq. ft.

OPERATING CFMs

up to 1,200 CFMs